

REVISION	DATE	PORTER No.
Change of Grade 5 Bolts	10-1-01	
		CUSTOMER No.

00225-000
HIGH STRENGTH GOAL (SUPER GOAL) with MOUNTING HARDWARE and NET

THIS PRINT IS THE PROPERTY OF PORTER ATHLETIC EQUIPMENT COMPANY AND MAY NOT BE REPRODUCED WITHOUT WRITTEN PERMISSION

Porter
 WORLD LEADER
 IN QUALITY SPORTS EQUIPMENT
 2500 S. 25th AVENUE
 BROADVIEW, ILLINOIS 60155
 www.porter-ath.com

DRAWING BY RJM	CHECKED BY EAS	PAGE No. B-225
-------------------	-------------------	-------------------

© COPYRIGHT 1994 PORTER ATHLETIC EQUIPMENT CO. ALL RIGHTS RESERVED.

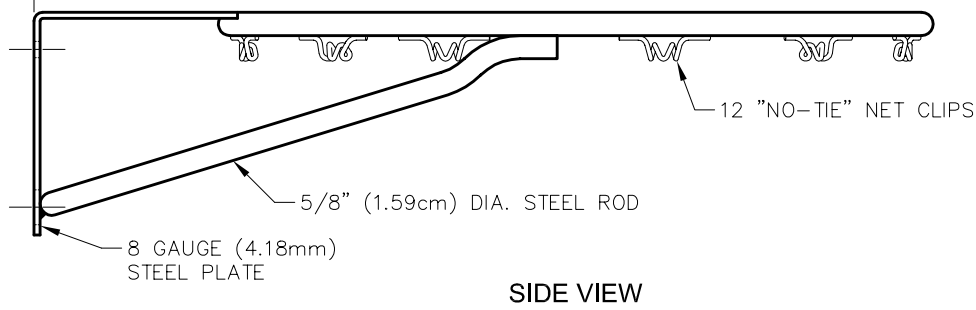
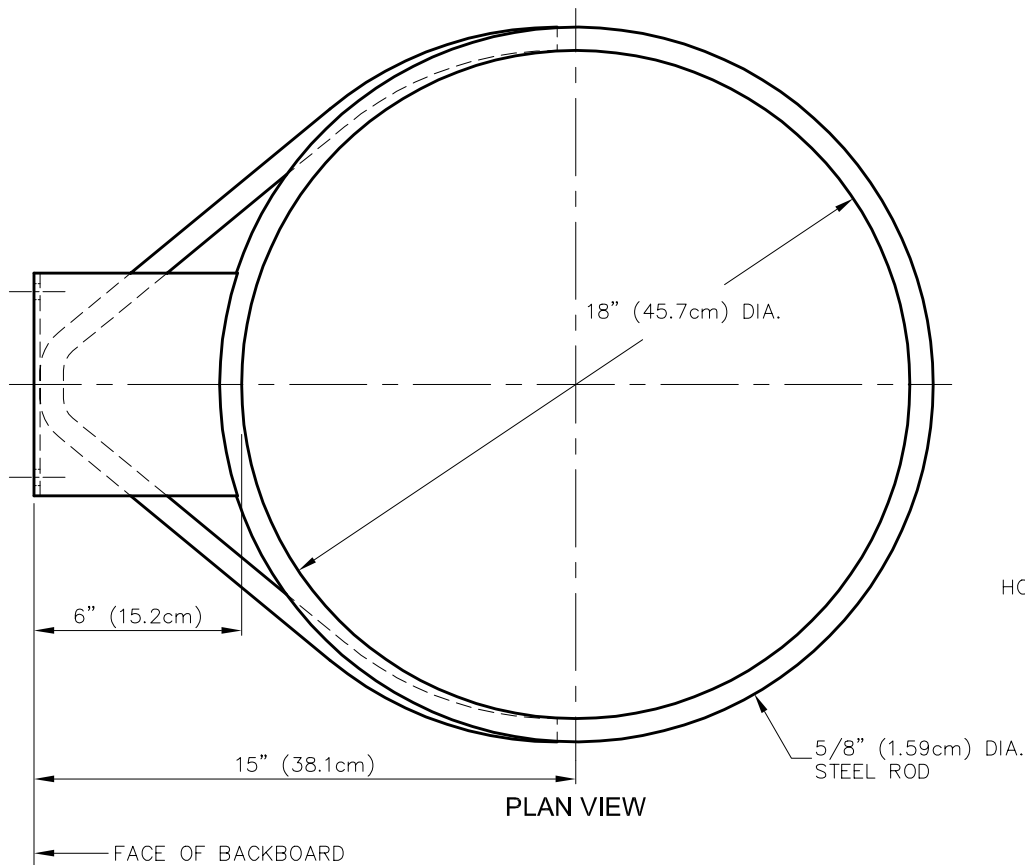

PARTS LIST			
No.	QTY.	DESCRIPTION	
1	1	GOAL 00026 007	GOAL WELDMENT
2	1	NETS 00001 000	WHITE NYLON NET
3	4	HDWE 01217 0E0	3/8" x 3 1/2" Lg. HEX HEAD TAP BOLT (Grade 5) Δ
4	4	HDWE 05004 0E0	3/8" FLATWASHER
5	4	HDWE 04002 0E0	3/8" LOCKWASHER
6	4	HDWE 03002 0E0	3/8" HEX NUT
7	4	PCAP 00040 002	3/8" THREAD PROTECTOR

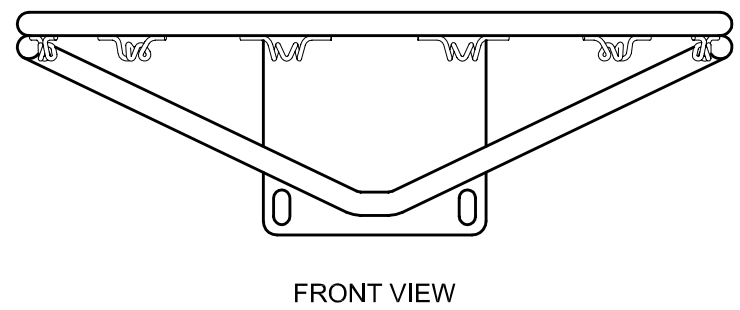
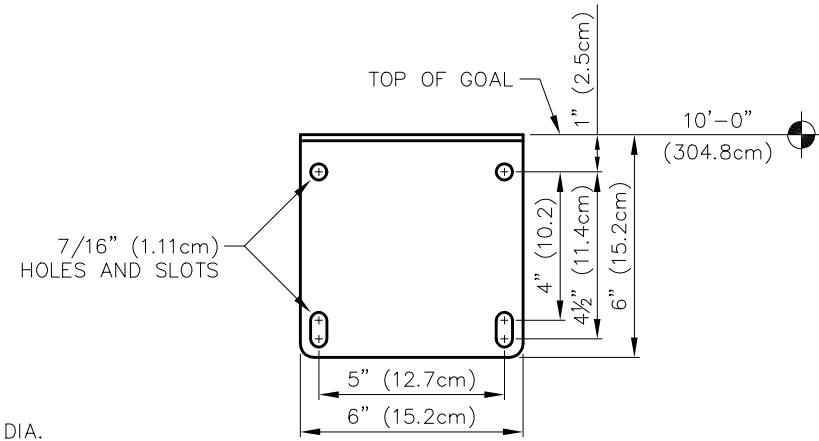

SPECIFICATIONS

PORTER No. 00225-000 HIGH STRENGTH GOAL (SUPER GOAL)

Rim shall be fabricated from 5/8" diameter high strength cold drawn alloy steel round formed to an 18" inside diameter ring. Inside of ring shall be positioned 6" from face of backboard by heavy, L-shaped, formed steel mounting plate with a 5" x 4" and 5" x 4-1/2" mounting hole centers for front mounting on standard glass, wood and fiberglass type backboards.

Rim shall be rigidly braced by means of a 5/8" diameter high strength cold drawn alloy steel round formed and welded in position for maximum support. Rim shall be provided with twelve "no-tie" net attachment clips for net attachment.

Goal assembly shall be capable of supporting up to an 800 pound load on outer edge of the rim and under extreme dynamic loading shall flex or deflect downward up to 2-3/4" without permanent set or deformation.

Goal shall be finished in a durable, official orange powder-coat finish.

Goal shall be finished complete with a high quality white nylon net and plated mounting hardware. Mounting bolts shall be SAE Grade 5.