

REVISION	DATE	PORTER No.
Change To Zinc Plated Grade 5 Bolts	6-1-00 10-1-01	
		CUSTOMER No.

© COPYRIGHT 1994 PORTER ATHLETIC EQUIPMENT CO. ALL RIGHTS RESERVED.
DATE 2-21-1994

00102-H00 and 00202-H00
DOUBLE-RIM FRONT-MOUNT GOAL
with MOUNTING HARDWARE and NET

THIS PRINT IS THE PROPERTY OF PORTER ATHLETIC EQUIPMENT COMPANY AND MAY NOT BE REPRODUCED WITHOUT WRITTEN PERMISSION

Porter
 WORLD LEADER
 IN QUALITY SPORTS EQUIPMENT
 2500 S. 25th AVENUE
 BROADVIEW, ILLINOIS 60155
 www.porter-ath.com

DRAWING BY RJM
 CHECKED BY EAS
 PAGE No. B-202

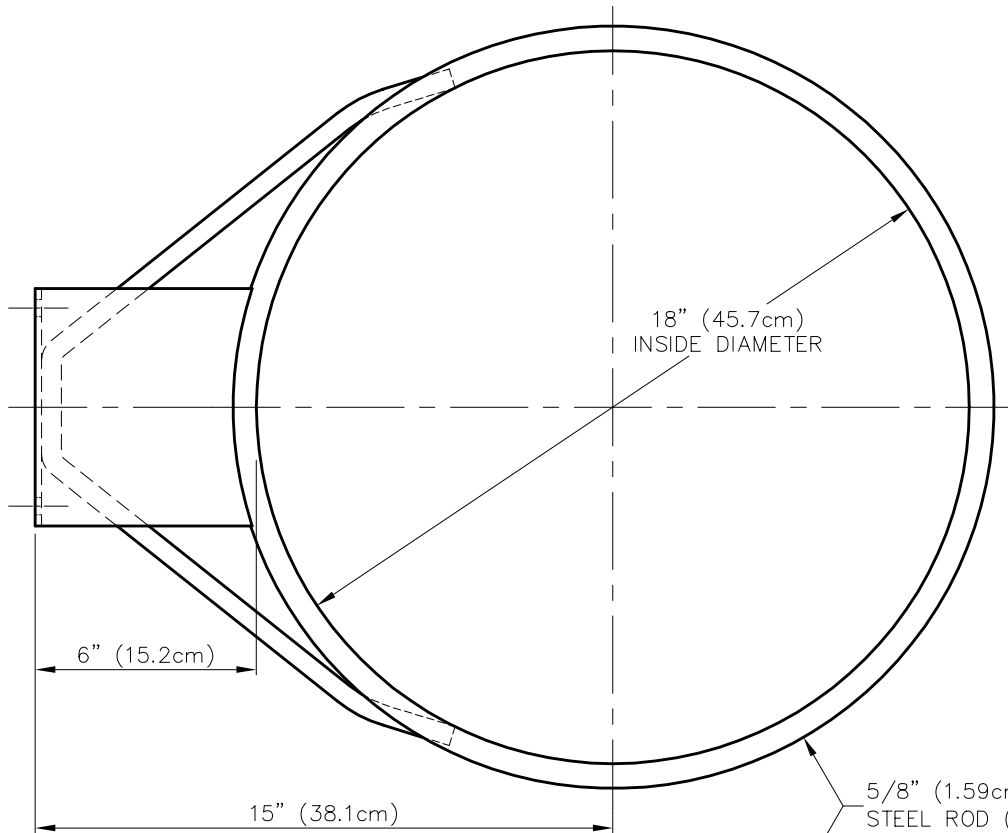

PLAN VIEW

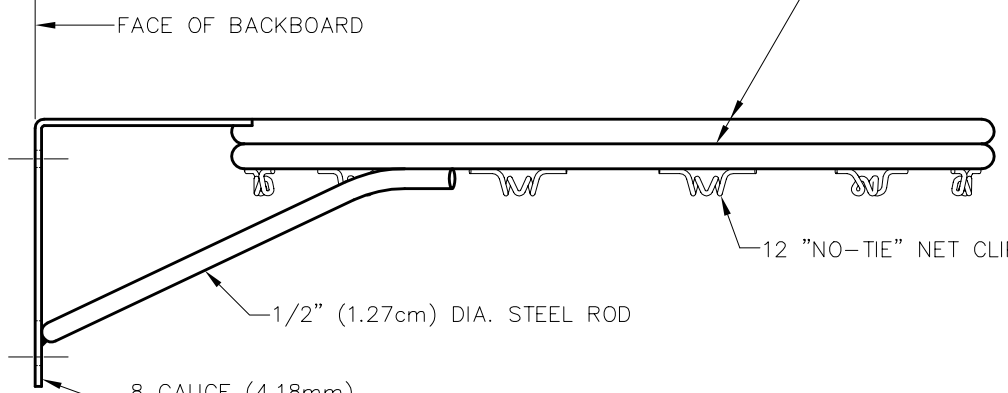

SIDE VIEW

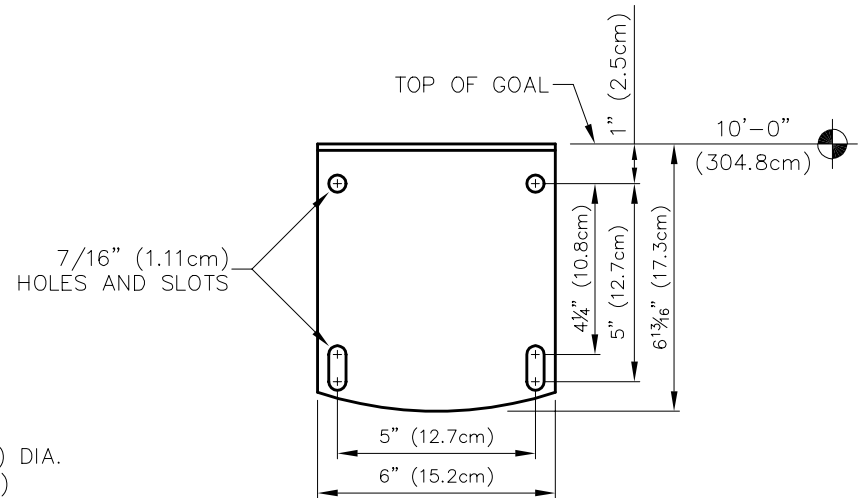

GOAL MOUNTING PLATE DETAIL

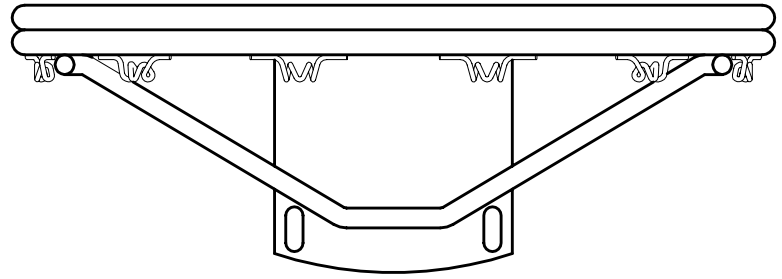

FRONT VIEW

PARTS LIST			
No.	00102 H00 QTY.	00202 H00 QTY.	DESCRIPTION
1	1		GOAL 00005 0E0 GOAL - Zinc Plated
1		1	GOAL 00005 007 GOAL - Orange
2	1	1	NETS 00001 000 WHITE NYLON NET (Not Shown)
3	4	4	HDWE 01217 0E0 3/8 x 3 1/2" Lg. HEX HEAD TAP BOLT (Grade 5)
4	4	4	HDWE 05004 0E0 3/8" FLATWASHER
5	4	4	HDWE 04002 0E0 3/8" LOCKWASHER
6	4	4	HDWE 03002 0E0 3/8" HEX NUT
7	4	4	PCAP 00040 002 THREAD PROTECTOR

- 00102-H00 DOUBLE-RIM FRONT-MOUNT GOAL - ZINC PLATED
- 00202-H00 DOUBLE-RIM FRONT-MOUNT GOAL - POWDER-COAT ORANGE

SPECIFICATIONS

PORTER No. 00202-H00 **DOUBLE-RIM FRONT-MOUNT GOAL** **WITH MOUNTING HARDWARE AND NET**

Rim shall be fabricated from 5/8" diameter cold drawn alloy steel round formed to an 18" inside diameter ring. A second ring shall be welded on top of first ring. Inside of rings shall be positioned 6" from face of backboard by heavy, L-shaped, formed steel mounting plate with 5" x 5" mounting hole centers for front mounting on standard glass, wood and fiberglass type backboards. (Goal compatible with all Center-Strut[®] direct-mount type support frames).

Rim shall be rigidly braced by means of a 1/2" diameter cold drawn alloy steel round formed and welded in position for maximum support. Rim shall be provided with twelve "no-tie" net attachment clips for net attachment.

Goal shall be finished in a durable, official orange powder-coat finish.

Goal shall be furnished complete with a high quality white nylon net and plated mounting hardware. Mounting bolts shall be SAE Grade 5.

PORTER No. 00102-H00 **DOUBLE-RIM FRONT-MOUNT GOAL** **WITH MOUNTING HARDWARE AND NET**

Same as No. 00202-H00 above, except goal is finished in a durable zinc-plated finish.