

FOLD-UP NETTING CURTAIN  
 (CURTAIN OPERATION AT CENTER)

90670-N00

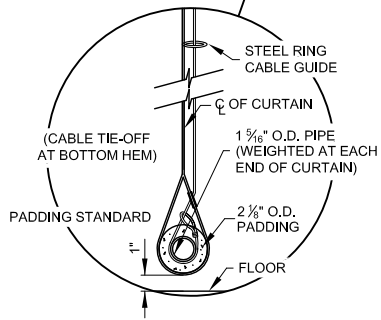

WORLD LEADER  
 IN QUALITY SPORTS EQUIPMENT  
 601 MERCURY DRIVE  
 CHAMPAIGN, ILLINOIS 61822  
 www.porterathletic.com

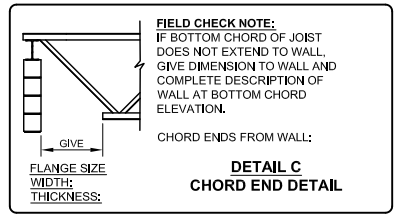
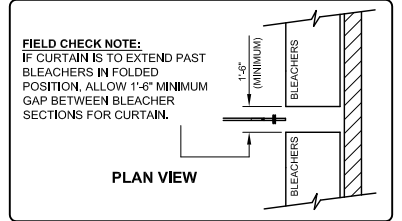
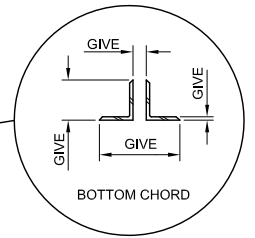
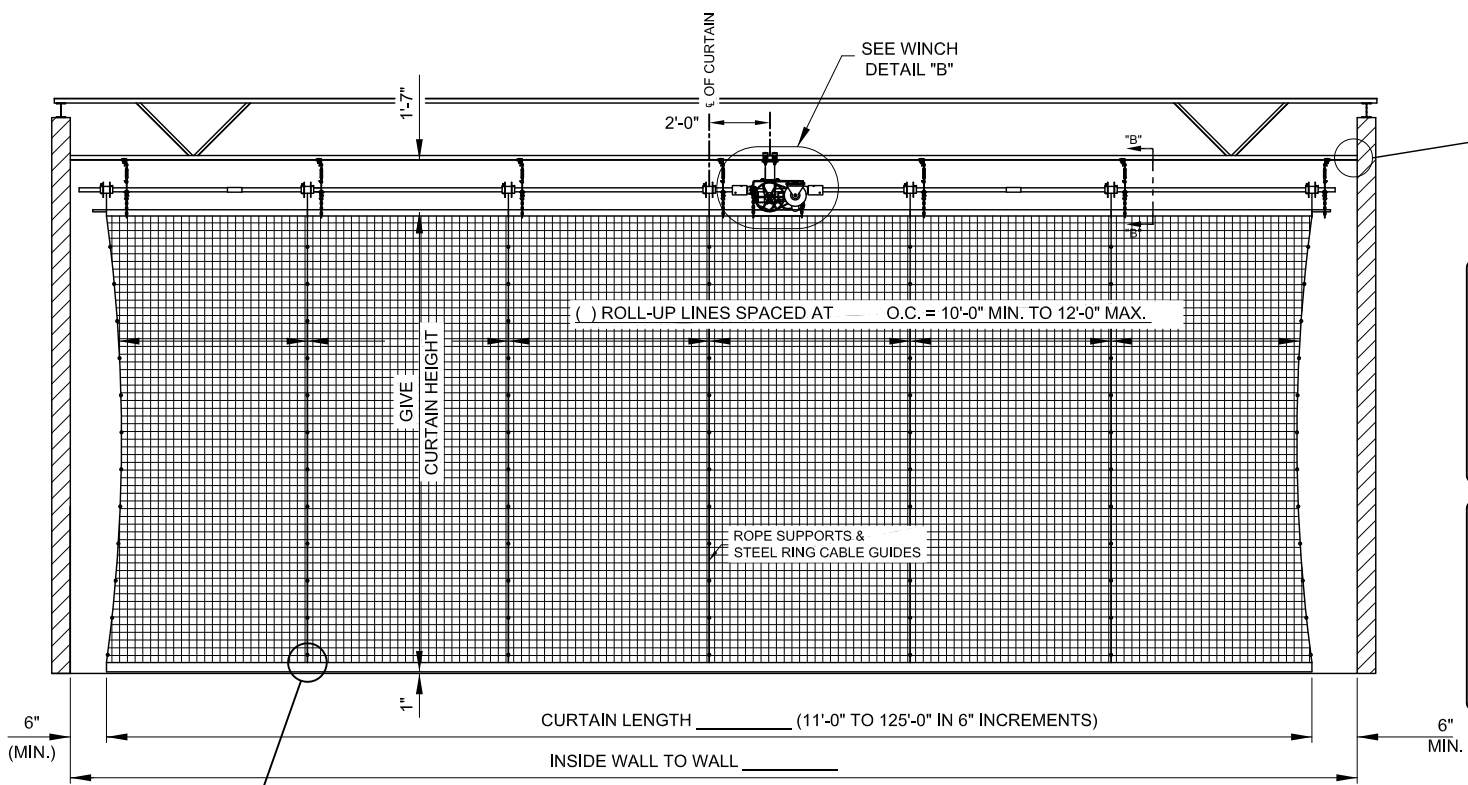

NET MATERIAL OPTIONS	BREAKING STRENGTH
#96 KNOTTED 1 1/4" MESH (DISCUS)	940 LBS
#36 KNOTTED 1 1/4" MESH (BASEBALL)	340 LBS
#21 KNOTTED 1 1/4" MESH (BASEBALL)	210 LBS
#420 KNOTLESS 3/4" MESH (GOLF)	135 LBS
#252 KNOTLESS 3/4" MESH (GOLF)	95 LBS

COLOR OPTIONS		
NETTING	VINYL POCKETS	ROPE SUPPORTS
BLACK	BLACK	BLACK
GREEN	GREEN	BLACK
WHITE	WHITE	WHITE

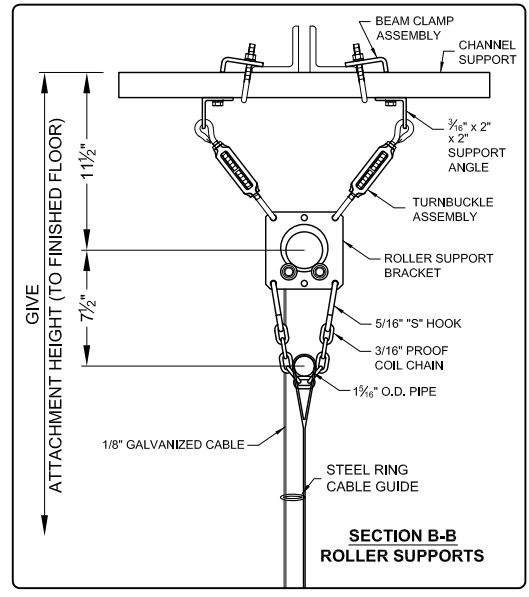
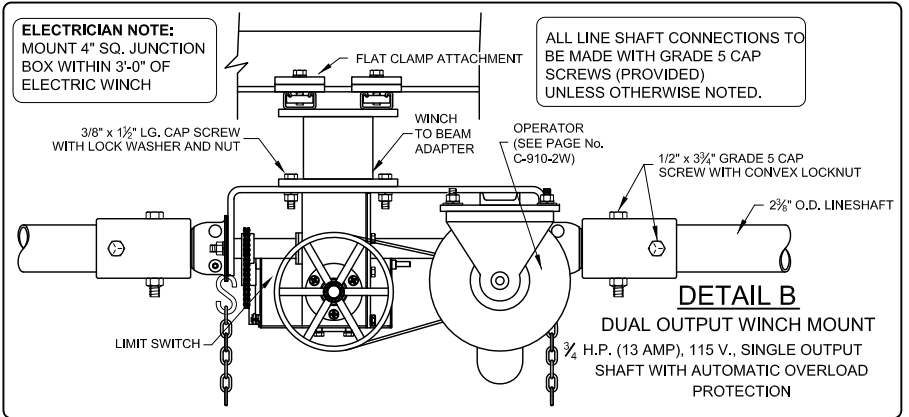

- 90670-N00 ROLL-FOLD GYMNASIUM DIVIDER NET CURTAIN (Curtain Operator at Center)  
 MAXIMUM SIZE = 125'-0" Lg. AND 3,000 Sq. Ft.  
 NET MATERIAL: \_\_\_\_\_, NET COLOR: \_\_\_\_\_

# SPECIFICATIONS

## PORTER No. 670 DIVIDER CURTAIN (Curtain Operator at Center)

PORTER No. 90670-N00 - FOLD-UP NETTING CURTAIN with PADDED BOTTOM SUPPORT TUBE

The curtain shall be made of a nylon netting material, specify below. The netting material shall meet the National Fire Protection Association Standard 701 Small Scale Test for flammability resistance.

Material	Mesh Size	Breaking Strength
#252 Knotless	3/4"	95 lbs
#420 Knotless	3/4"	135 lbs
#21 Knotted	1 3/4"	210 lbs
#36 Knotted	1 3/4"	340 lbs
#96 Knotted	1 3/4"	940 lbs

The net curtain is available in the following colors – Black, Green, and White (specify). Note: Rope hem and rope supports will be black if the netting is black or green. The rope hem and rope supports will be white if the netting white.

Top of curtain to be fabricated with a vinyl pocket to conceal continuous 1-5/16" O.D. steel tube extending the full length of the curtain to ensure proper support. Tube shall be supported from roller assembly supports on adjustable chains not exceeding 12'-0" centers.

Curtain shall be hoisted by 1/8" dia. vandal-proof galvanized cable (2,100 lb. breaking strength each cable, spaced between 10'-0" and 12'-0" apart) passing thru steel ring type cable guides on approximate 24" centers. Bottom end of cables to terminate around 1-5/16" O.D. tube in bottom pocket, secured with concealed micropress, swaged type clamps. Bottom support tube shall be encased in a 2-1/8" O.D., closed cell shock absorbing type protective foam rubber padding. Cables shall be routed thru steel ring cable guides on one side of the curtain to fold the curtain in a compact accordion fold arrangement the curtain is hoisted.

Upper ends of hoist cables shall terminate into individual hoist drums positioned on continuous zinc-plated 2-3/8" O.D. tube line shaft arrangement. Line shaft shall turn in special support assemblies equipped with four steel ball bearing wheel rollers. Each support assembly shall be positioned adjacent to a cable hoist drum. Support assemblies shall be secured to structural roof framing supports by means of threaded rods and support chains to provide structural integrity and accommodate all slopes or building camber.

All metal parts not zinc-plated shall be powder coated. (If special painting or colors are required, specify final painting by painting contractor.)

See Page No. C-910-2W for specifications on 3/4 H.P. electric operator.